

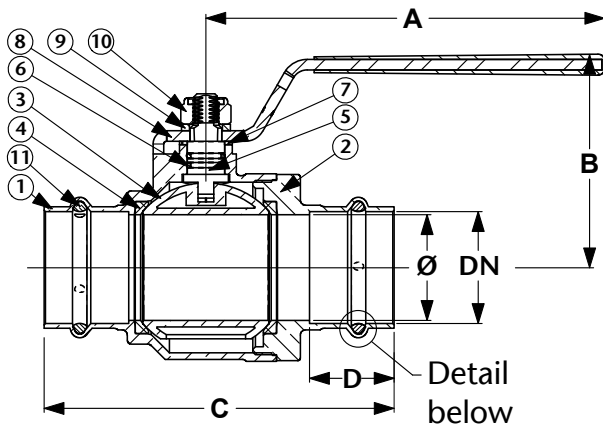

PN16 DZR Press Ball Valve

Features

- Universal M & V Press 15mm to 35mm
- Dedicated M & V Profiles 42mm & 54mm (See diagram)
- Full Bore
- DZR Brass Body
- PTFE Seats
- EPDM 'O' Rings
- Pre-Press Leak Detection
- WRAS Approved



'M' Press (DN42)

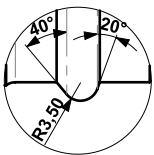

'M' Press (DN54)

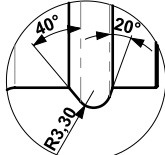

'V' Press (DN42+54)

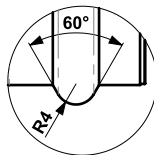

NB: Sizes 15mm to 35mm can be pressed with both 'M' and 'V' press jaws. Always use the appropriate 'M' or 'V' press sling to press sizes 42mm and 54mm

Technical Data

Max Pressure 16 Bar
Working Temperature -20°C to +140°C

Dimensions in mm

This data sheet is designed as a guide and should not be regarded as wholly accurate in every detail. We reserve the right to amend the specification of any product without notice.

Pressure / Temperature

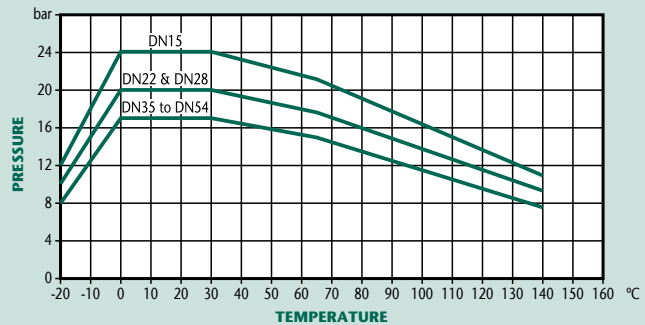

DN	15	22	28	35	42	54
A	90	90	110	110	150	150
B	47	52	57	65	81	89
C (M Press)	78	91	99	107	133	155
C (V Press)	78	91	99	107	133	163
D (M Press)	22	25	27	27	32	33
D (V Press)	22	25	27	27	32	37
Kgs	0.19	0.31	0.49	0.72	1.17	1.72

N.	Part Name	Materials
1	Body	DZR Brass
2	Screwed End	DZR Brass
3	Ball	Brass Chrome Plated
4	Ball Gaskets	PTFE
5	Stem	Brass
6	O-Ring	FKM 70 SH
7	Anti-Friction Ring	PTFE
8	Handle	Steel
9	Washer	Brass
10	Self-Locking Nut	Steel
11	O-Ring	EPDM 70 PEROX